



ACRA KAM-500

CONTROL

FBM/103

S200 beta mode FireWire bus monitor

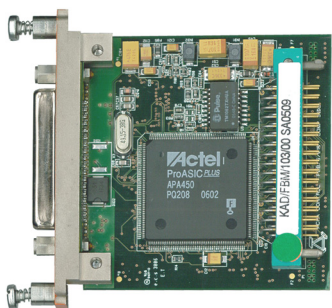

FEATURES

- IEEE 1394b compatible
- Physical layer has a transformer coupled interface
- Monitors IEEE 1394b at a signal rate of 200Mbps (S200b)
- Coherent parsing of isochronous and asynchronous stream packets by channel ID/message ID
- Transaction level tagging (time, count, status, info)
- Maximum data payload size of 2KB per packet
- Triple-buffering of parsed packets
- Discards other asynchronous, bus configuration and PHY packets
- Provides transaction counters and error detection

APPLICATIONS

- FireWire beta mode bus monitoring

DESCRIPTION

The FBM/103 monitors FireWire (IEEE 1394b) traffic. It acts as a leaf in the FireWire bus topology and to all other nodes on the bus, the link layer and transaction layer appear to be deactivated.

The FBM/103 parses isochronous or asynchronous stream packets. All other traffic is ignored (configuration traffic, PHY packets and asynchronous transactions). Selected packets and associated tag information are stored in one of 65 triple-buffered parser slots. Each parser slot contains up to 1036 16-bit words: 1030 words of packet content; three words of timestamp information; one word containing the transaction number; one word containing the packet size; and one word containing buffer information.

FireWire packets are parsed in two stages. First, packets are filtered to accept only isochronous and asynchronous stream packets (traffic with transaction code A_{16}). Then the channel ID and message ID (third quadlet in the FireWire packet) are used to classify the packet and determine which of the 65 parser slots the packet is written to. Unique channel ID and message ID combinations can be targeted to any of the 64 available parser slots.

Parser slot 0 may be configured to operate as a "catch all" slot where any channel and message IDs not mapped to specific parser slots will be routed.

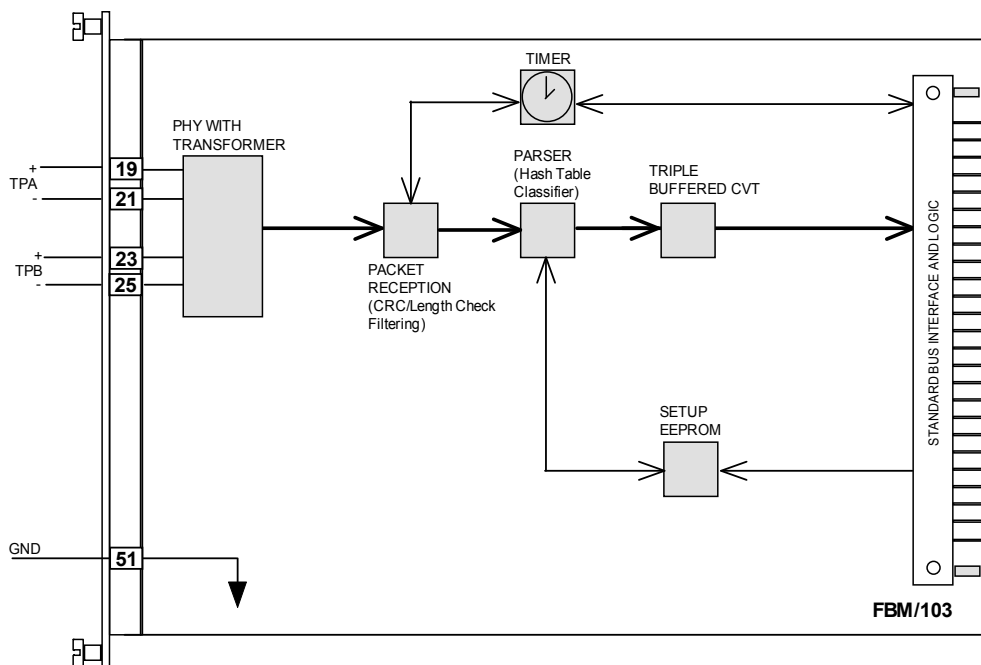

Filtering and parsing in the FBM/103

Selection guide and ordering information

Selection Paths

Airborne Data Acquisition → KAM-500 → Modules → Bus → FireWire

Ordering Information

Part Number	Mating Connector	Description
KAD/FBM/103/B	CON/KAD/002/CP	FBM/103/B module with 52-way double density module top connector

By default, the standard mating connector above is included with each module in the shipment. Its part number will be added to the Confirmation of Order unless an alternative option is specified (see the *Cables* data sheet).

Revision History

Revision	Differences	Status
FBM/103/B	Transformer coupled FireWire bus monitor with enhanced parsing	Recommended for new programs
FBM/103	First release	Not recommended for new programs

Related Products

Module	Details
FBM/102	FireWire bus monitor, operates in bilingual mode up to S400 signalling
KSM-500	This module is supported by the KSM-500 suite of software tools

Related Documentation

Document	Details
DOC/DBK/001	KAM-500 Databook
DOC/MAN/018	KSM-500 Databook
DOC/GBK/002	Environmental Qualifications Handbook

Specifications

General specifications

Parameter	Min.	Typ.	Max.	Units	Condition/Details
Slots	–	–	1	–	Can be placed in any user-slot in any combination.
Mass	–	74	–	g	Design metric is grams.
	–	2.61	–	oz	
Height above chassis					For recommended clearance requirements see the CON/KAD/002/CP data sheet.
bare connector	–	–	11	mm	Design metric is millimeters.
bare connector	–	–	0.43	inch	
Access rate	–	–	2	Msp/s	Maximum combined access rate for read and write.
Power consumption					
+5V	195	–	324	mA	
total power	0.972	–	1.62	W	
Environmental ratings					See <i>Environmental Qualifications Handbook</i> .
operating temperature	-40	–	85	°C	Chassis base/side plate temperature.
storage temperature	-55	–	105	°C	

FireWire bus interface

Parameter	Min.	Typ.	Max.	Units	Condition/Details
Inputs	–	–	1	–	IEEE 1394b compatible.
Sampling rate					
TPA	–	–	2	Msp/s	
TPB	–	–	2	Msp/s	
Voltage	200	–	800	mV	1394b differential input voltage.
Data rate	100	–	200	Mbps	FireWire S200B and S100B rates.

Setting up parameters

For parameter Report

Set-up data	Choice	Default/Example	Notes
Name	Report	FBM103_Report	Received transactions error report.
Base Unit	Unitless	Unitless	R(15) Error occurred since last read. R[14:4] Reserved for future use. R[3:0] Error code.
maximum	8008 ₁₆	8001 ₁₆	CRC error occurred since last read.
minimum	0001 ₁₆	000F₁₆	
Data Format	BitVector	BitVector	
Size In Bits	1 to 16	16	

For parameter Sts1394

Set-up data	Choice	Default/Example	Notes
Name	Sts1394	FBM103_Sts_1394	IEEE 1394b port status.
Base Unit	Unitless	Unitless	R[15:8] Reserved for future use. R[7:2] PHY_ID. R(1) Reserved for future use. R(0) Link is connected.
maximum	00FD ₁₆	0001 ₁₆	Link is connected. Node has an ID of 0.
minimum	0	0	Nothing is connected to the port.
Data Format	BitVector	BitVector	
Size In Bits	1 to 16	16	

For parameter TotalTrnCnt

Set-up data	Choice	Default/Example	Notes
Name	TrnCnt	FBM103_Trms_Cnt	Transaction counter, counts all fully parsed transactions, counter can overflow.
Base Unit	Unitless	Unitless	
maximum	FFFF ₁₆	0002 ₁₆	2 packets were parsed.
minimum	0	0	0 packets were parsed.
Data Format	Offset binary	Offset binary	
Size In Bits	1 to 16	16	

For parameter PackageData

Set-up data	Choice	Default/Example	Notes
Name	PackageData	FBM103_TrnData	IEEE 1394b packet. Pkt_Data_0 is first word received. The first word received is the packet header. 16 MSB bits.
Base Unit	Unitless	Unitless	
maximum	FFFF ₁₆	0002 ₁₆	
minimum	0	0	
Data Format	Offset binary	Offset binary	
Size In Bits	1 to 16	16	

For parameter TrnInfo

Set-up data	Choice	Default/Example	Notes
Name	TrnInfo	FBM103_TrnInfo	Information tag for this parsed transaction. This is a non-zero value.
Base Unit	Unitless	Unitless	R(15) 1 indicates that there is no message stored (EMPTY) R(14) 1 indicates this message was read before (STALE) R(13) 1 indicates this message overwrote another (SKIPPED) R[12:0] Reserved for future use, may be non-zero value.
maximum	8000 ₁₆	8000₁₆	Parser slot empty, nothing parsed since power-up.
minimum	0	0	New message parsed, no messages skipped.
Data Format	BitVector	BitVector	
Size In Bits	1 to 16	16	

For parameter TrnTimeHi

Set-up data	Choice	Default/Example	Notes
Name	TrnTimeHi	FBM103_TrnTimeHi	Hours and minutes time of start of transaction.
Base Unit	Unitless	Unitless	[12:11] Tens of Hours D[10:7] Hours D[6:4] Tens of Minutes D[3:0] Minutes
maximum	11D9 ₁₆	0002 ₁₆	Message was received when TimeHi was 0 hours, 2 minutes.
minimum	0	0	
Data Format	BitVector	BitVector	
Size In Bits	1 to 16	16	

For parameter TrnTimeLo

Set-up data	Choice	Default/Example	Notes
Name	TrnTimeLo	FBM103_TrnTimeLo	Seconds and centiseconds time of the start of transaction.
Base Unit	Second	Second	R[14:12] Tens of seconds R[11:8] Ones of seconds R[7:4] Tenths of seconds R[3:0] Hundredths of seconds
maximum	5999 ₁₆	0002 ₁₆	Message was received when TimeLo was 0.02 seconds.
minimum	0	0	
Data Format	BinaryCodedDecimal	BinaryCodedDecimal	
Size In Bits	1 to 16	16	

For parameter TrnTimeMicro

Set-up data	Choice	Default/Example	Notes
Name	TrnMicroTime	FBM103_TrnMicroTime	Microsecond time of the start of the acquisition cycle.
Base Unit	Second	Second	
maximum	9999 ₁₆	0002 ₁₆	Message was received when TimeMicro was 2µs.
minimum	0	0	
Data Format	BinaryCodedDecimal	BinaryCodedDecimal	
Size In Bits	1 to 16	16	

For parameter TrnCnt

Set-up data	Choice	Default/Example	Notes
Name	TrnCnt	FBM103_TrnCnt	Transaction number.
Base Unit	Unitless	Unitless	
maximum	FFFF ₁₆	0002 ₁₆	Message was the 2nd parsed packet.
minimum	0	0	
Data Format	Offset binary	Offset binary	
Size In Bits	1 to 16	16	

For parameter TrnSize

Set-up data	Choice	Default/Example	Notes
Name	TrnSize	FBM103_TrnSize	Packet size in quadlets, with header, header CRC, data, and data CRC.
Base Unit	Unitless	Unitless	
maximum	0203 ₁₆	0103 ₁₆	Message has a 1024B data payload (total packet size is 1036B).
minimum	4	4	Message has a 4Byte data payload (total packet size us 16B).
Data Format	Offset binary	Offset binary	
Size In Bits	1 to 16	16	



It is recommended that names are less than 20 characters, have no white space, bold or italic characters or contain any of the following five characters "/><\.

Setting up instrumentation

This module uses the X-Module-Firewire-Monitor-1.1 XidML schema. (See <http://www.xidml.org>).

For messages

Set-up Data	Choices	Default/Example	Notes
Manufacturer			
name	ACRA CONTROL	ACRA CONTROL	
part reference	KAD/FBM/103	KAD/FBM/103	ACRA CONTROL part number.
serial number	Fixed 6 characters	FE1234	Unique number for each module.
Settings			
MessageBuffer	Parser(0) to Parser (64)	Parser(0)	This element is used to store the name of messages that are buffered together.
Name	Message Name	Msg_0_J5_0	This element is used to store the name of a message.
fill value	0 to FFFF ₁₆	1023	Value used to fill empty parser slots. This is the default value for all parameters beginning with Trn, except TrnInfo which is 8000 ₁₆ when nothing is parsed. Also all PackageData are filled with this value when nothing is parsed.

Setting up packages

This module uses the X-Firewire-1.1 XidML schema. (See <http://www.xidml.org>).

For transaction channels

Set-up Data	Choices	Default/Example	Notes
Synchronous	No	No	
Packages per acquisition cycle	1	1	
Properties			
number of words	0 to 1029	4	
HashBinaryValue	1,0,X Up to 32 bits	1,0000000000000000 0000000000000000	The channel, Message High and Message Low ID are stored in a hashbinary. If the OffsetIndex_Bits is 8, the value contains the channel. If the OffsetIndex_Bits is 64, the value is the Message High and Message Low ID's.
OffsetIndex_Bits		8, 64	Specifies the offset in bits of the location containing the specified value.
Content			
parameter	no character limit	P1	
offset words	0 to 1029	0	

Error codes for the FBM/103

0₁₆	Reserved for future use.
1₁₆	CRC error in header or payload was detected.
2₁₆	FIFO overflow. This indicates that the amount of incoming traffic that needs to be parsed exceeds the processing capability of the module. Filtering must be tightened.
3₁₆	Reserved for future use.
4₁₆	Length mismatch. The length defined in the header does not match the actual received amount of data.
5₁₆-7₁₆	Reserved for future use.
8₁₆	Packet too big. A packet was received that exceeds the maximum payload of 2048 bytes.
9₁₆-D₁₆	Reserved for future use.
E₁₆	Reserved for future use.
F₁₆	Default value after power up.

Getting the most from the FBM/103/B

Triple Buffering

Triple buffering supports concurrent access to the packet being read, packet being received, and an interim packet. The transaction information (TrnInfo) word associated with each packet is used to indicate whether the packet is 'stale' (buffer has been read before) or 'skipped' (buffer has been overwritten).

Packet Classification

FireWire isochronous (or asynchronous stream) packets can be stored in one of 65 parser slots or dropped (not stored). The decision on which parser slot to store the packet or to

drop the packet is based on three fields of information from each packet: the 6-bit Channel ID; the upper 16 bits of the Message ID; and the lower 16 bits of the Message ID (Message ID is the third quadlet in the packet). An explicit data value or a special wildcard value "ALL" can be specified for each of these fields. The combination of these three fields plus a destination parser slot is defined as a rule. Up to 255 rules can be specified. Rules can allow for multiple packets to be stored in a single parser slot. And rules may overlap. The compiler sorts and processes rules in a deterministic order.

The following table is an example set of rules that can be defined. Rules may be entered in any order. The compiler sorts the rules as shown in this table. Rules for a channel are grouped together and then within this group explicit rules are processed first, followed by wildcard rules.

Example classification names

Rule	Parser Slot	Channel ID	Message Hi ID	Message Lo ID	Order Rules Processed	Description
0	1	1	ALL	ALL	1	All packets with a Channel ID of 1 will be routed to parser slot 1.
1	2	2	ALL	CAFE	2	All packets with a Channel ID of 2 and the Message Lo ID of CAFE will be routed to parser slot 2.
2	3	3	0	0	3	Packets with a Channel ID of 3, a Message Hi ID of 0 and a Message Lo ID of 0 will be routed to parser slot 3.
3	4	3	0	ALL	4	Packets that match this pattern, excluding packets that match rule 2, will be routed to parser slot 4.
4	5	3	ALL	0	5	Packets that match this pattern, excluding packets that match rule 2 & 3, will be routed to parser slot 5.
5	6	3	ALL	ALL	6	Packets that match this pattern, excluding packets that match rule 2 & 3 & 4, will be routed to parser slot 6.
6	62	ALL	DEAD	DEAD	7	Packets that match this pattern will be routed to parser slot 62. For Channel ID 1, this rule will have no effect. For Channel ID 2, this rule will affect all packets not covered by rule 1. For Channel ID 3, this rule will have no effect. The reason is that rules 3-6 have higher priority than this rule.
7	63	ALL	BODE	ALL	8	Packets that match this pattern will be routed to parser slot 63. Rules 0 to 6 have higher priority than this rule.
8	64	ALL	ALL	ABBA	9	Packets that match this pattern will be routed to parser slot 64. This rule has the lowest priority.

Connector pinout of the KAD/FBM/103

Pin	Name	See specifications table	Comment
1	DNC		Do not connect
2	DNC		Do not connect
3	DNC		Do not connect
4	DNC		Do not connect
5	DNC		Do not connect
6	DNC		Do not connect
7	DNC		Do not connect
8	DNC		Do not connect
9	DNC		Do not connect
10	DNC		Do not connect
11	DNC		Do not connect
12	DNC		Do not connect
13	DNC		Do not connect
14	DNC		Do not connect
15	DNC		Do not connect
16	DNC		Do not connect
17	NC		No connection
18	NC		No connection
19	TPA+	FireWire bus interface	Receive Data+ (IEEE convention uses TPA)
20	NC		No connection
21	TPA-	FireWire bus interface	Receive Data- (IEEE convention uses TPA*)
22	NC		No connection
23	TPB+	FireWire bus interface	Transmit Data+ (IEEE convention uses TPB)
24	NC		No connection
25	TPB-	FireWire bus interface	Transmit Data- (IEEE convention uses TPB*)
26	NC		No connection
27	DNC		Do not connect
28	NC		No connection
29	NC		No connection
30	NC		No connection
31	NC		No connection
32	NC		No connection
33	NC		No connection
34	NC		No connection
35	NC		No connection
36	DNC		Do not connect
37	NC		No connection
38	DNC		Do not connect
39	DNC		Do not connect
40	DNC		Do not connect
41	DNC		Do not connect
42	DNC		Do not connect
43	DNC		Do not connect
44	DNC		Do not connect
45	DNC		Do not connect
46	NC		No connection
47	NC		No connection
48	NC		No connection
49	NC		No connection
50	DNC		Do not connect
51	GND		
52	CHASSIS		

Data sheet text and specifications are subject to change without notice. © 2008 ACRA CONTROL. All rights reserved.
 ACRA CONTROL INC, 44145 Airport View Drive, Hollywood, MD 20636, USA, Phone: (301) 373-9220, Fax: (301) 373-9223, Email: info@acracontrol.com
 ACRA CONTROL LTD, Landscape House, Landscape Road, Dublin 14, Ireland, Phone: +353-1-2951264, Fax: +353-1-2951265, Email: mail@acracontrol.com
 www.acracontrol.com