

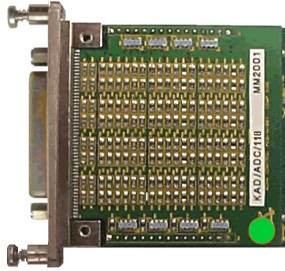

ACRA KAM-500

ADC/118

CONTROL 12-ch. bridge A/D converter with voltage excitation, balancing & signal conditioning



FEATURES

- 12 full or 1/2-bridge, potentiometer or differential-ended (D/E) input channels
- Simultaneous sampling 16-bit A/D for each channel
- High accuracy
- Programmable input range and balance current per channel
- Programmable excitation per group of three channels
- 8th order Butterworth filter with programmable cutoff frequency per channel
- Short to ground on any channel does not affect others
- Up to 12,000 samples per second per channel
- Up to 3kHz bandwidth
- Bipolar excitation and balancing before instrumentation amplifier

APPLICATIONS

- High impedance bridge sensors
- Differential voltage measurement
- Strain gage measurement

DESCRIPTION

The ADC/118 is used to condition and digitize up to twelve differential-ended (D/E) analog channels. At the heart of the ADC/118 is a hard-wired state-machine that oversamples all channels at a rate between 48ksps and 96ksps and digitally filters any noise above the user-programmable cutoff frequency.

This is achieved using cascaded, half-band, finite-impulse-response (FIR) filters followed by an 8th order Butterworth IIR filter with a default cutoff point set at one quarter of the sampling frequency ($f_c=f_s/4$). All signals are sampled simultaneously. Thus, when several channels are sampled at different sampling rates, at the start of an acquisition cycle all channels will be aligned.

The ADC/118 is similar to the ADC/120 but includes support for channel balancing. The ADC/118 is available with three different input ranges ($\pm 10V$, $\pm 1V$, $\pm 100mV$). The input range must be specified when ordering.

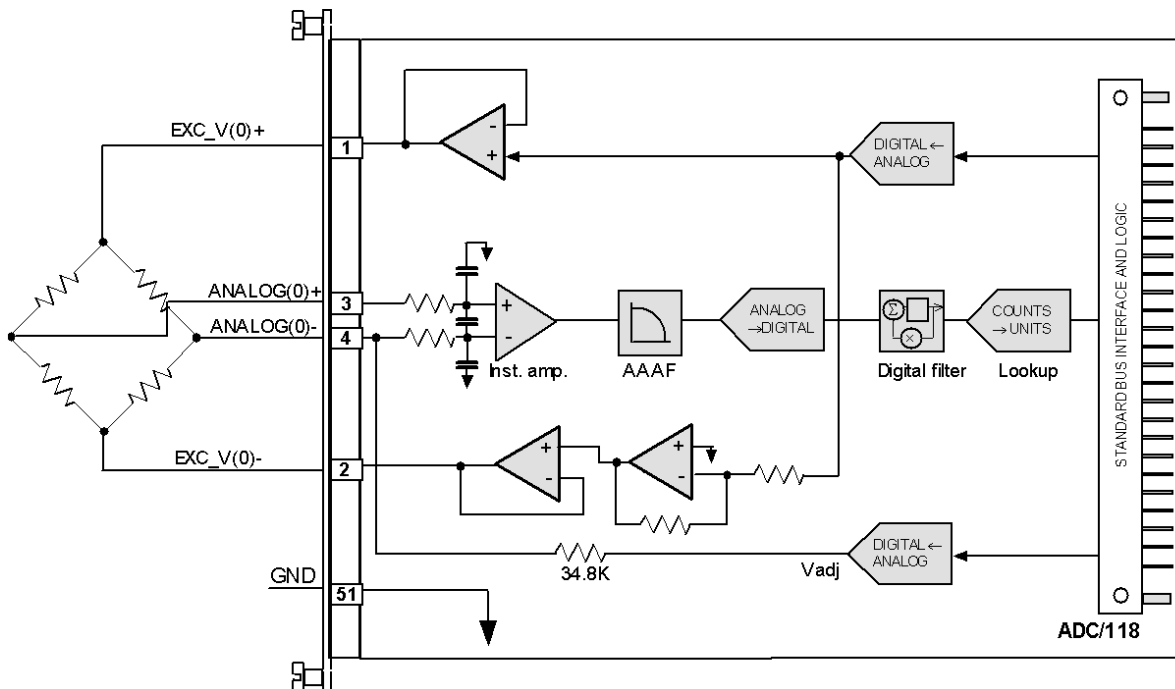

First of 12 channels on the ADC/118

Selection guide and ordering information

Selection Paths

Airborne Data Acquisition → KAM-500 → Modules → Analog → Bridge

Ordering Information

Part Number	Mating Connector	Description
KAD/ADC/118/10V	CON/KAD/002/CP	ADC/118/10V module with 52-way double density connector
KAD/ADC/118/1V	CON/KAD/002/CP	ADC/118/1V module with 52-way double density connector
KAD/ADC/118/100M	CON/KAD/002/CP	ADC/118/100m module with 52-way double density connector
KAM/ADC/118/10V	ACC/CON/008/04	ADC/118/10V module with 51-way micro-miniature connector
KAM/ADC/118/1V	ACC/CON/008/04	ADC/118/1V module with 51-way micro-miniature connector
KAM/ADC/118/100M	ACC/CON/008/04	ADC/118/100M module with 51-way micro-miniature connector

By default, the standard mating connector above is included with each module in the shipment. Its part number will be added to the Confirmation of Order unless an alternative option is specified (see the *Cables* data sheet).

The ADC/118 uses power from the +7V for excitation and therefore can not be used with CHS/04L, CHS/05F or CHS/03F. If the maximum excitation current is drawn from each channel, then the maximum number of ADC/118s per chassis is limited to five.

Revision History

Revision	Differences	Status
ADC/118/10V	ADC/118 with $\pm 10V$ input range	Recommended for new programs
ADC/118/100M	ADC/118 with $\pm 100mV$ input range	Recommended for new programs
ADC/118/1V	ADC/118 with $\pm 1V$ input range	Recommended for new programs

Related Products

Module	Details
ADC/120	12 channel bridge A/D converter module, with excitation and signal conditioning
KSM-500	This module is supported by the KSM-500 suite of software tools

Related Documentation

Document	Details
TEC/NOT/001	Strain gages and ideal bridges
TEC/NOT/002	Bridge balancing and shunt calibration
TEC/NOT/017	Accuracy on KAM-500 modules
DOC/MAN/018	KSM-500 Databook
DOC/GBK/002	Environmental Qualification Handbook
DOC/DBK/001	KAM-500 Databook