

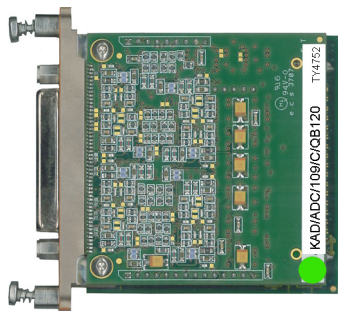

# ACRA KAM-500 ADC/109/QB120

C O N T R O L

8-ch. A/D converter, with current exc. and sig. cond. for ¼-bridge 120Ω strain gages



## FEATURES

- Eight ¼-bridge (3-wire) input channels for ¼-bridge 120Ω strain gages
- 16-bit A/D simultaneous sampling on all channels
- High accuracy
- Programmable excitation and range per channel
- 8<sup>th</sup> order Butterworth filter with programmable cutoff frequency per channel
- Excitation shorted to ground on any channel does not affect others
- Excitation before instrumentation amplifier
- Up to 24,000 samples per second per channel
- Up to 6kHz bandwidth
- Enhanced mechanical strength between motherboard and daughterboard
- High impedance per channel when powered off

## APPLICATIONS

- 120Ω ¼-bridge strain gages

## DESCRIPTION

The ADC/109/QB120 provides independent excitation for up to eight channels and is intended for ¼-bridge 120Ω-strain-gage type applications. Each channel has a separate programmable amplifier, programmable filter and A/D converter.

At the heart of the ADC/109/QB120 is a hard-wired state-machine that over-samples all channels at a rate between 96ksps and 192ksps, and digitally filters any noise above the user programmable cutoff frequency. This is achieved using cascaded, half-band, decimate by 2, 15 tap, finite-impulse-response (FIR) filters with 32-bit coefficients followed by an 8<sup>th</sup> order Butterworth IIR filter with a default cutoff point set at a quarter of the sampling frequency.

The current through the gage is programmable (up to 25mA in 6.35μA steps) and is kept constant. As the resistance changes, the voltage across the gage (and hence as seen by the amplifier) changes linearly.

All signals are sampled simultaneously. This means that even when several channels are sampled at different sampling rates, the sample at the start of the acquisition will always be synchronized.

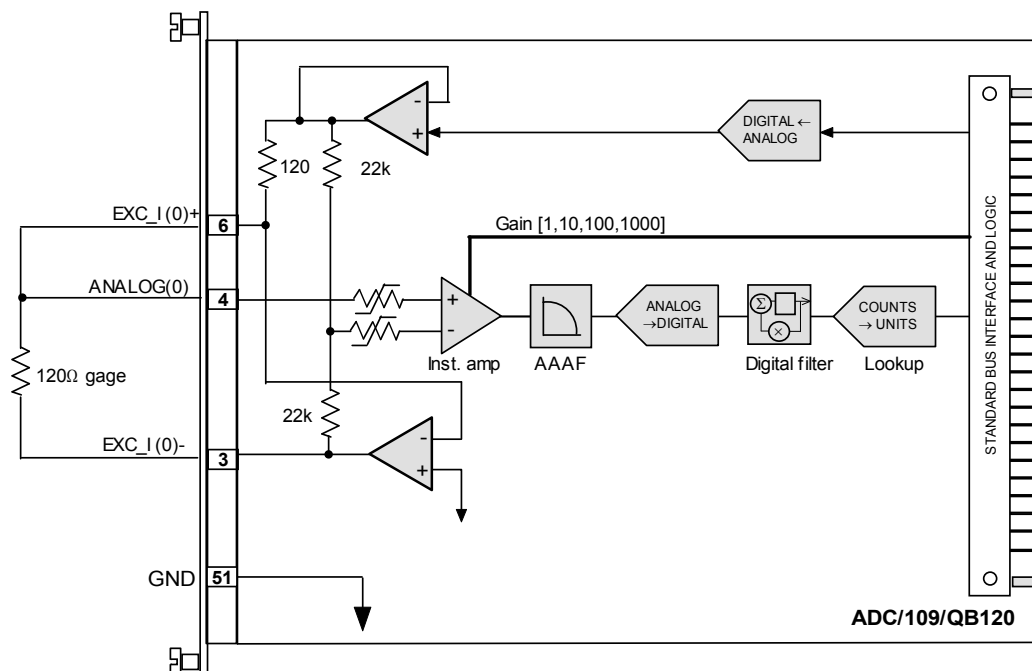

First of eight channels on the ADC/109/QB120

## Selection guide and ordering information

### Selection Paths

Airborne Data Acquisition → KAM-500 → Modules → Analog → Bridge

### Ordering Information

Part Number	Description
KAD/ADC/109/C/QB120	8-ch. A/D converter, with current exc. and sig. cond. for ¼-bridge 120Ω strain gages

By default, the standard mating connector, CON/KAD/002/CP, is included with each module in the shipment. Its part number will be added to the Confirmation of Order unless an alternative option is specified (see the *Cables* data sheet).

The ADC/109/QB120 uses power from the ±7V for excitation and therefore cannot be used with the CHS/04L, CHS/05F or CHS/03F chassis.

### Revision History

Revision	Differences	Status
ADC/109/C/QB120	High impedance per channel when powered off, enhanced mechanical strength and improved format switching	Recommended for new programs
ADC/109/B/QB120	First release	Not recommended for new programs

### Related Products

Module	Details
ADC/109/B/QB350	8 channel A/D converter, with excitation and signal conditioning for ¼-bridge 350Ω strain gages
ADC/109/B/S1	8-channel bridge A/D converter module, with voltage excitation, external/internal balancing and signal conditioning
ADC/109/B/S2	8-channel bridge A/D converter module, with voltage excitation, internal balancing, sense and signal conditioning
ADC/009/QB350	The ADC/009/QB350 is an older module with slower throughput on the backplane, less accuracy and longer filter delays. The ADC/109/B/QB350 is recommended for new programs.
KSM-500	This module is supported by the KSM-500 suite of software tools

### Related Documentation

Document	Details
TEC/NOT/001	Strain gages and ideal bridges
TEC/NOT/002	Bridge balancing and shunt calibration
TEC/NOT/017	Accuracy on KAM-500 modules
TEC/NOT/019	An introduction to digital filtering
DOC/MAN/018	KSM-500 Databook
DOC/HBK/002	Environmental Qualification Handbook
DOC/DBK/001	KAM-500 Databook